

＜油圧パイルハンマ概要＞ HYDRAULIC PILE HAMMER

型式 Type		単位 Monetary	S-90
能力 Ability	最大打撃エネルギー Max. Blow energy on the Pile	kNm	90.0
	最小打撃エネルギー Min. Blow energy on the Pile	kNm	2.0
	最大打撃エネルギーでの打撃回数 Blow Rate at Max Blow Energy	回/分 bl/min	50
質量 Mass	ラム Ram	ton	4.5
	ハンマ (ラム含まず) Hammer (in air)	ton	4.7
	平型アンビル Flat-bottom anvil	ton	0.8
	パイルスリーブ Pile sleeve incl. ballast	ton	4.2
	総質量 (大気中) Total mass in air	ton	14.2
	総質量 (水中) Total mass submerged	ton	11.0
寸法 Measure	本体外径 Outside dia. of hammer	mm	610
	本体長 Length of hammer	mm	7,880
	適用最大パイル径 Sleeve for piles up to	mm	900
	スリーブ内パイル長 Length of pile in sleeve	mm	1,455
	スリーブを付けた時のハンマ長 Length of hammer with sleeve and ballast	mm	9,630
油圧仕様 Hydraulic specification	最大作動圧 Max. Operating pressure	bar	350
	最大作動油流量 Max. Operating oil flow	リットル/分 l/min	220
	油圧ホース (内径) Hydraulic hose (the inside diameter)	mm	32

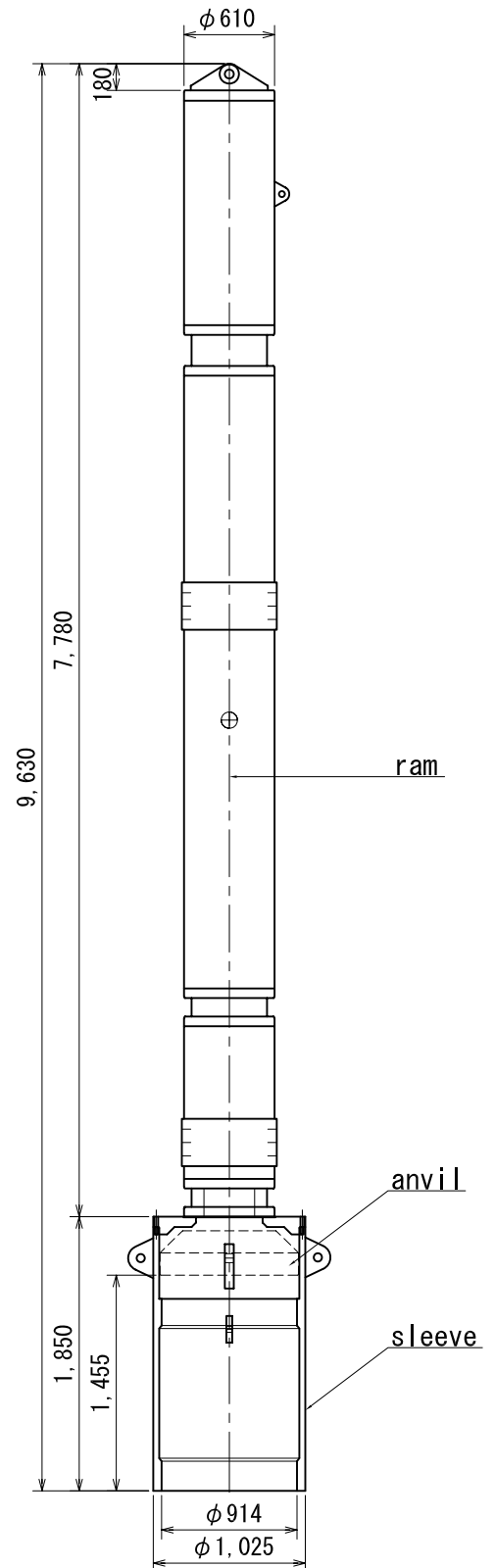

＜油圧パワーパック概要＞ HYDRAULIC POWER PACK

型式 Type		単位 Monetary	P-250	型式 Type		単位 Monetary	P-250
型式 Type	Engine model	Volvo/6cyl. Water cooled Volvo水冷直列6気筒		質量 Mass	本体 Net weight	kg	3,300
	Cooling system	Radiator air cooling			本体 (油脂を含む) Weight incl. fuel and oil	kg	5,000
	Serial number	— (No. 2)					
油圧仕様 Hydraulic specification	最大油圧 Max. pressure	bar	380	寸法 Measure	長さ Length	mm	3,500
	最大油流量 Max. oil flow	リットル/分 l/min	220		幅 Width	mm	1,300
	出力 Power	kW	160		高さ Height	mm	1,870 (Max. 2,020)